

SATCOM Transceivers & Up/Down Converters

Series 80000 & 85000



IMAGine.

Innovative | Multifunction | Adaptable

Integrated Microwave Assemblies

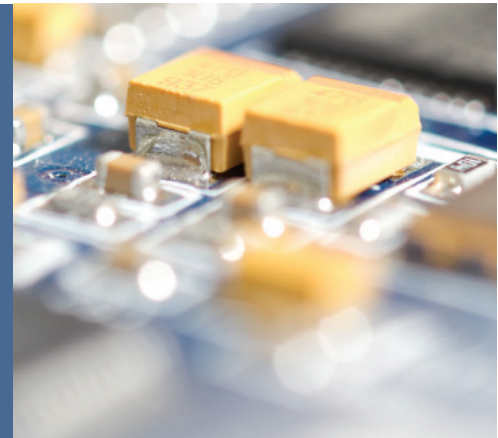

narda

an  communications company

nardamicrowave.com

Series 80000 SATCOM Transceivers for Ku, X and Ka Bands

These products use Narda's Ultimate SMT IMA module technology to provide compact high performance transceivers. Three models are offered covering X, Ku and Ka bands. Each transceiver contains a BDC, BUC, SSPA, microprocessor and all necessary control functions.

- Small and Light Weight
15.0" x 6.25" x 3.25"
15lbs.
- High Linear Power Output at Low Spectral Regrowth Levels
- High Dynamic Range Receiver
- Interface – Ethernet or RS-485
- Low Power Consumption
- Optional Antenna Mounted Ka Band or X Band LNA available for Ultra Low Noise Figure



Functional Block Diagram / Series 80000

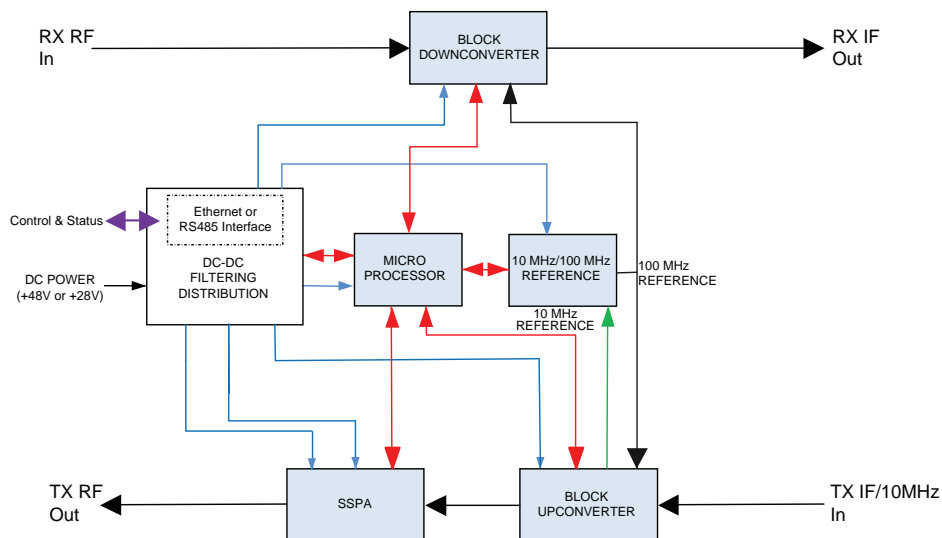

Outline Drawing / Models 81000 & 82000 (X and Ku Bands)

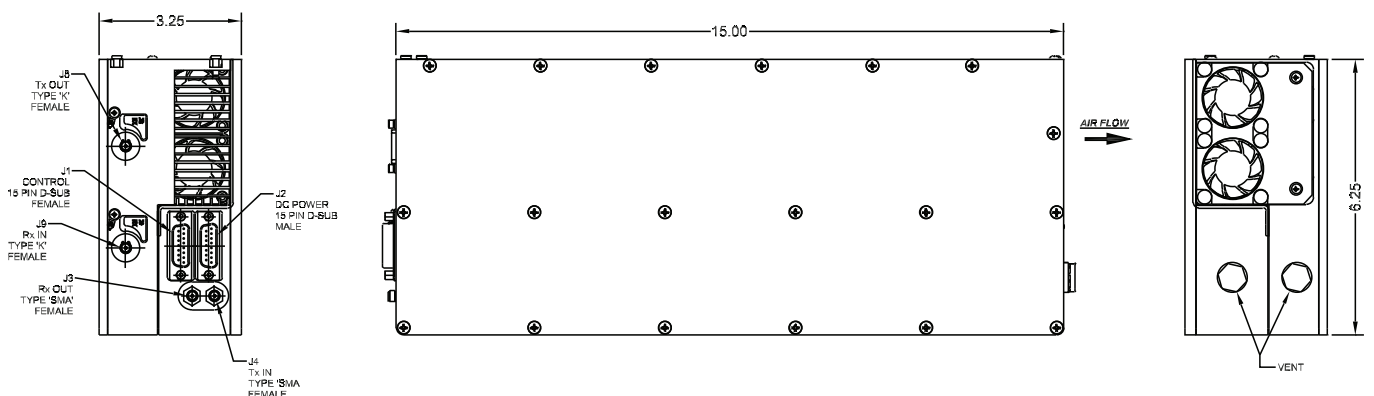

Outline Drawing / Model 83000 (Ka Band)

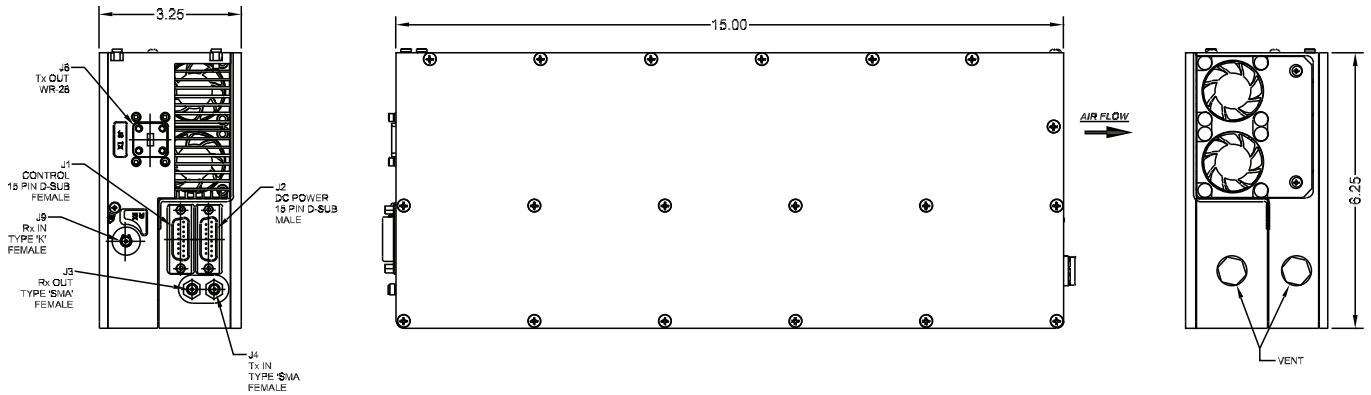

Up/Down Converters for Ku, X, and Ka Bands / Series 85000

These up/down converter subsystems are offered for those applications where the customer prefers to use an external SSPA. They contain all the parts of the 80000 series less the SSPA and offered in a package of reduced size and weight. Three models are offered covering X, Ku, and Ka bands. Each up/down converter contains a BDC, BUC, microprocessor and all necessary control functions.

- Small and Light Weight
8.0" x 7.0" x 3.12"
10lbs.
- High Dynamic Range Receiver
- Interface – Ethernet or RS-485
- Low Power Consumption
- Optional Antenna Mounted Ka Band or X Band LNA available for Ultra Low Noise Figure

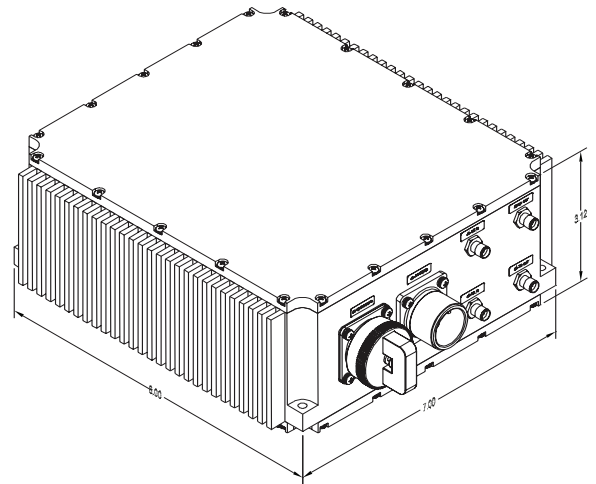

Functional Block Diagram / Series 85000

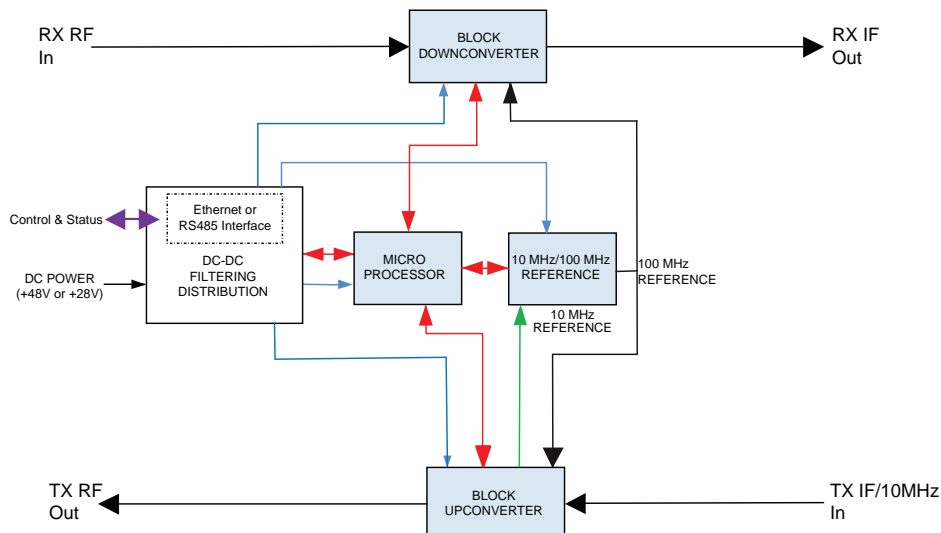

Series 80000 Technical Performance

ITEM	PARAMETER	Ka BAND - MODEL 83000	Ku BAND - MODEL 81000	X BAND - MODEL 82000
UPCONVERTER+ SSPA				
1	IF Frequency	1.0 - 2.0 GHz	0.95 - 1.7 GHz	0.95 - 1.45 GHz
2	RF Frequency	30 - 31 GHz	13.75 -14.50 GHz	7.9 - 8.4 GHz
3	Linear Output Power	39 dBm (8W), Typ. @ -30 dBc Spectral Regrowth	41.14 dBm (13 W) @ -26 dBc Spectral Regrowth	40 dBm (10 W) w/ optional external filter 41.1 dBm (13W) w/o optional external filter @ -30 dBc Spectral Regrowth
4	Conversion Gain	55 dB min	55 dB min	50 dB min
5	Gain Control	30 dB min, 0.25 dB Steps	Optional 18 dB min, 0.25 dB Steps	Optional 18 dB min, 0.25 dB Steps
6	Gain Flatness Narrowband Over Whole Band Over Temperature	± 0.75 dB max over 80 MHz ± 2.0 dB max ± 1.5 dB max	± 0.5 dB max over 40 MHz ± 1.5 dB max ± 1.5 dB max	± 0.5 dB max over 40 MHz ± 1.0 dB max ± 1.5 dB max
7	Tx Noise in Rx Band	-165 dBm/Hz max (20.2 - 21.2 GHz)	-156 dBm/Hz max (10.95 -12.75 GHz)	-156 dBm/Hz max (7.25 - 7.75 GHz) w/ optional external filter (Note 1)
8	In Band Spurious	-50 dBc max at Pout = 39 dBm (Includes 2x1 on 1 GHz IF input)	-50 dBc max at Pout = 41.14 dBm	-50 dBc max at Pout = 40dBm
9	Harmonic Suppression	-60 dBc max at Pout = 39 dBm	-60 dBc max at Pout = 41.14 dBm	-60 dBc max at Pout = 40 dBm
10	LO Leakage	-60 dBc max at Pout = 39 dBm	-60 dBc max at Pout = 41.14 dBm	-60 dBc max at Pout = 40 dBm
DOWNCONVERTER				
11	IF Frequency	1.0 - 2.0 GHz	0.95 - 1.7 GHz (Band 1), 0.95 - 1.5 GHz (Band 2), 0.95 - 1.45 GHz (Band 3)	0.95 - 1.45 GHz
12	RF Frequency	20.2 - 21.2 GHz	10.95 - 11.7 GHz (Band 1), 11.7 - 12.25 GHz (Band 2), 12.25 - 12.75 GHz (Band 3)	7.25 - 7.75 GHz
13	Output P1dB	16 dBm min	12.5 dBm min	12.5 dBm min
14	Conversion Gain	37 dB min	30 dB min	30 dB min
15	Gain Control	30 dB min, 0.25 dB Steps	Optional 15 dB min, 0.25 dB Steps	Optional 15 dB min, 0.25 dB Steps
16	Gain Flatness Narrowband Over Whole Band Over Temperature	± 0.5 dB max over 80 MHz ± 1.5 dB max ± 1.5 dB max	± 0.5 dB max over 40 MHz ± 2.0 dB max ± 1.5 dB max	± 0.5 dB max over 40 MHz ± 2.0 dB max ± 1.5 dB max
17	Noise Figure @ 1L	15 dB max	20 dB max	20 dB max
18	Output IP3	26 dBm min	22.5 dBm min	22.5 dBm min
19	In Band Spurious	-65 dBc max at Pout = 0 dBm (Excludes 2x1 on 1 GHz IF Output)	-50 dBc max at Pout = 10 dBm	-50 dBc max at Pout = 10 dBm
20	Harmonic Suppression	-44 dBc max at Pout = 0 dBm	-50 dBc max at Pout = 0 dBm	-50 dBc max at Pout = 0 dBm
GENERAL				
21	Power Consumption @ P1 dB	154 W Max	174 W Max	140 W Max
22	DC Supply	Optional 28 V or 48 V	Optional 28 V or 48 V	Optional 28 V or 48 V
23	Dimensions	15.0 x 6.25 x 3.25 inches typ	15.0 x 6.25 x 3.25 inches typ	15.0 x 6.25 x 3.25 inches typ
24	Weight	15 lbs typ	15 lbs typ	15 lbs typ
25	Operating Temperature Range	-30 to +50°C min	-30 to +50°C min	-30 to +50°C min
26	10 MHz Reference	External/Internal	External/Internal	External/Internal
27	Static Phase Noise	MIL-STD-188-164A Compliant	MIL-STD-188-164A Compliant	MIL-STD-188-164A Compliant

Note 1. Please consult factory for performance without external filter.

All specifications are subject to change without notice.

Series 85000 Technical Performance

ITEM	PARAMETER	Ka BAND - MODEL 85300	Ku BAND - MODEL 85100	X BAND - MODEL 85200
UPCONVERTER				
1	IF Frequency	1.0 - 2.0 GHz	0.95 - 1.7 GHz	0.95 - 1.45 GHz
2	RF Frequency	30 - 31 GHz	13.75 - 14.50 GHz	7.9 - 8.4 GHz
3	P1dB	20 dBm min	15 dB min	15 dB min
4	Conversion Gain	33 dB min	30 dB min	30 dB min
5	Gain Control	30 dB min, 0.25 dB Steps	Optional 18 dB min, 0.25 dB Steps	Optional 18 dB min, 0.25 dB Steps
6	Gain Flatness Narrowband Over Whole Band Over Temperature	± 0.5 dB max over 80 MHz ± 1.25 dB max ± 1.5 dB max	± 0.25 dB max over 40 MHz ± 0.75 dB max ± 1.5 dB max	± 0.25 dB max over 40 MHz ± 0.75 dB max ± 1.5 dB max
7	Noise Figure @ Max Gain	20 dB max	20 dB max	20 dB max
8	Output IP3	25 dBm min	25 dBm min	25 dBm min
9	In Band Spurious	-60 dBc max at Pout = 0 dBm (Includes 2x1 on 1 GHz IF Input)	-60 dBc max at Pout = 0 dBm	-60 dBc max at Pout = 0 dBm
10	LO Leakage	-50 dBc max at Pout = 0 dBm	-60 dBc max at Pout = 0 dBm	-60 dBc max at Pout = 0 dBm
DOWNCONVERTER				
11	IF Frequency	1.0- 2.0GHz	0.95 - 1.7 GHz (Band 1), 0.95 - 1.5 GHz (Band 2), 0.95 - 1.45 GHz (Band 3)	0.95 - 1.45 GHz
12	RF Frequency	20.2 - 21.2 GHz	10.95 - 11.7 GHz (Band 1), 11.7 - 12.25 GHz (Band 2), 12.25 - 12.75 GHz (Band 3)	7.25 - 7.75 GHz
13	Output P1 dB	16 dBm min	12.5 dBm min	12.5 dBm min
14	Conversion Gain	37 dB min	30 dB min	30dB min
15	Gain Control	30 dB min, 0.25 dB Steps	Optional 15 dB min, 0.25 dB Steps	Optional 15 dB min, 0.25 dB Steps
16	Gain Flatness Narrowband Over Whole Band Over Temperature	± 0.5 dB max over 80 MHz ± 1.5 dB max ± 1.5 dB max	± 0.5 dB max over 40 MHz ± 2.0 dB max ± 1.5 dB max	± 0.5 dB max over 40 MHz ± 2.0 dB max ± 1.5 dB max
17	Noise Figure @ IL	15 dB max	20 dB max	20 dB max
18	Output IP3	26 dBm min	22.5 dBm min	22.5 dBm min
19	In Band Spurious	-65 dBc max at Pout = 0 dBm (Excludes 2x1 on 1 GHz IF Output)	-50 dBc max at Pout = 10 dBm	-50 dBc max at Pout = 10 dBm
20	Harmonic Suppression	-44 dBc max at Pout = 0 dBm	-50 dBc max at Pout = 0 dBm	-50 dBc max at Pout = 0 dBm
GENERAL				
21	Power Consumption @ P1 dB	32 W Typ	28 W Typ	28 W Typ
22	DC Supply	Optional 28 V or 48 V	Optional 28 V or 48 V	Optional 28 V or 48 V
23	Dimensions	15.0 x 6.25 x 3.25 inches typ	15.0 x 6.25 x 3.25 inches typ	15.0 x 6.25 x 3.25 inches typ
24	Weight	14 lbs typ	14 lbs typ	14 lbs typ
25	Operating Temperature Range	-30 to +50°C min	-30 to +50°C min	-30 to +50°C min
26	10 MHz Reference	External/Internal	External/Internal	External/Internal
27	Static Phase Noise	MIL-STD-188-164A Compliant	MIL-STD-188-164A Compliant	MI L -STD-188-164A Compliant

All specifications are subject to change without notice.

Model 83000 Ka Band Transceiver – Typical Performance

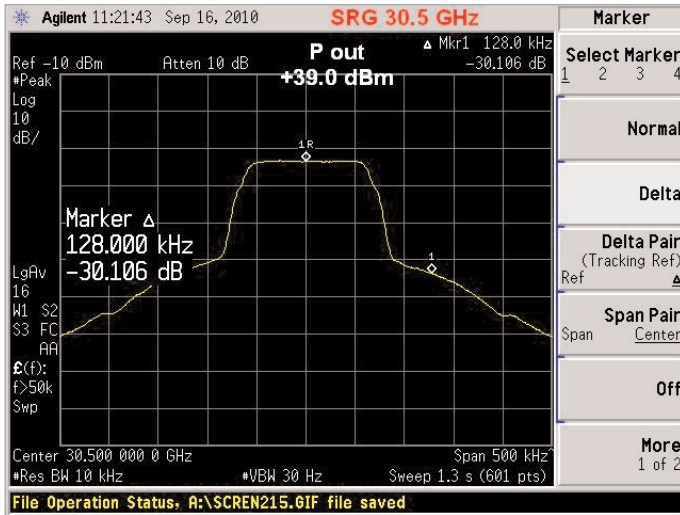

Spectral Regrowth @8 Watts Output

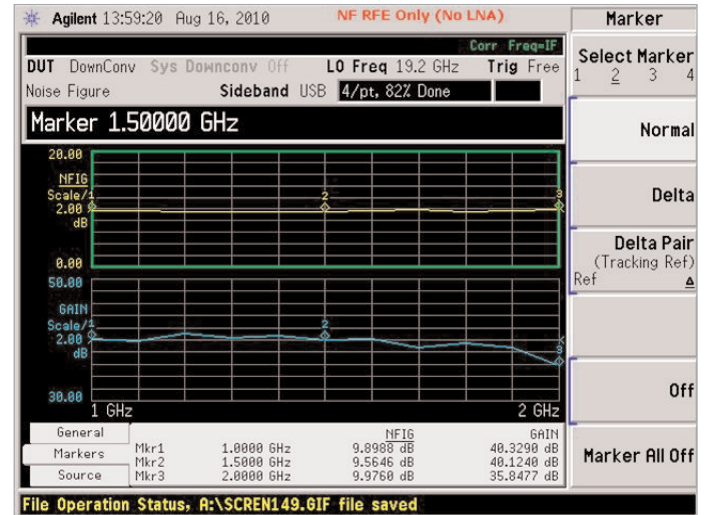

Noise Figure

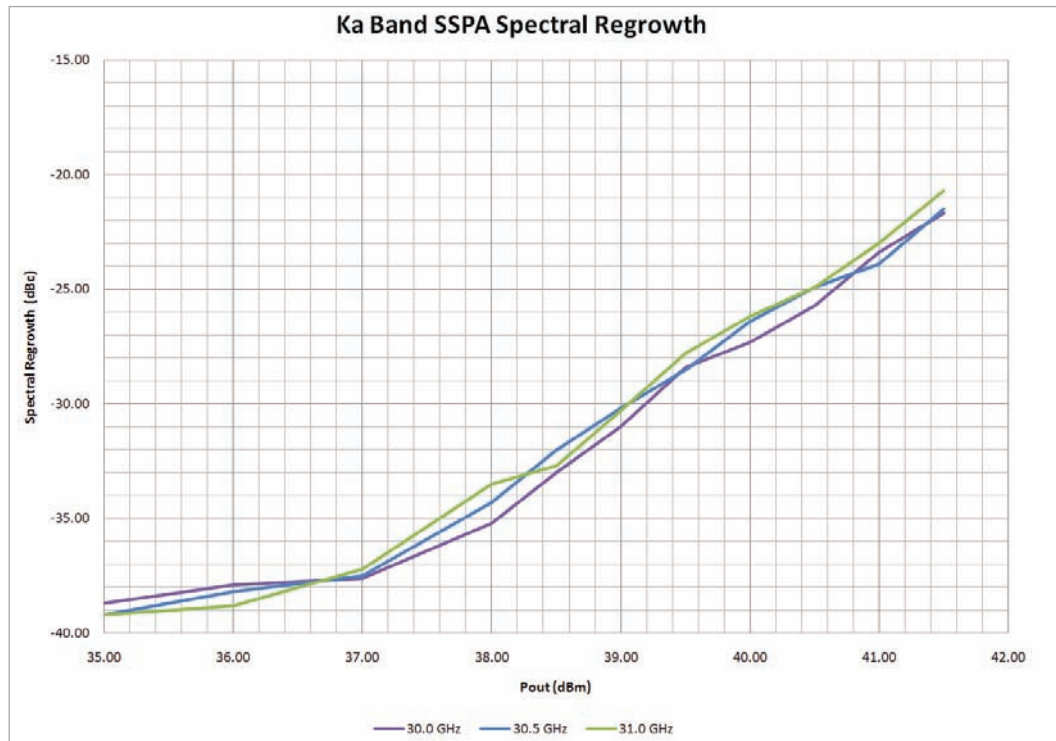

*No one goes to greater lengths
 for smaller wavelengths.*

narda

an **L3** communications company

435 Moreland Road, Hauppauge, NY 11788
 Tel: 631.231.1700 • Fax: 631.231.1711
 e-mail: nardaeast@L-3com.com

www.nardamicrowave.com